



HWCE Tx/Rx
4K HDMI & USB 2.0 over HDBaseT™ Wall-Plate Extender
USER MANUAL



PureLink™
22-10 State Rt. 208
Fair Lawn, NJ 07410USA
Tel: +1.201.488.3232
Fax: +1.201.621.6118
E-mail: sales@purelinkav.com

For order support, please contact your local dealer.
For technical support, please contact us at support@purelinkav.com.



HWCE TX/RX USER MANUAL
VERSION 1.1

Thank You for Purchasing This Product

For optimal performance and safety, please read these instructions carefully before connecting, operating or adjusting this product. Please keep this manual for future reference.

Surge Protection Device Recommended

This product contains sensitive electrical components that may be damaged by electrical spikes, surges, electric shock, lighting strikes, etc. Use of surge protection systems is highly recommended in order to protect and extend the life of your equipment.

Table of Contents

| | |
|--|-----------|
| INTRODUCTION | 3 |
| PRODUCT FEATURES | 3 |
| PACKAGE CONTENTS | 3 |
| SPECIFICATIONS | 4 |
| OPERATION & CONTROL FUNCTIONS | 5 |
| TRANSMITTER (FRONT PANEL) | 5 |
| TRANSMITTER (REAR PANEL) | 5 |
| RECEIVER (FRONT & BACK PANELS) | 6 |
| APPLICATION EXAMPLES | 7 |
| POC (POWER OVER CABLE) APPLICATION | 7 |
| BIDIRECTIONAL RS-232 CONTROL APPLICATION | 8 |
| WARRANTY | 9 |
| PURELINK™ THREE (3) YEAR LIMITED WARRANTY | 9 |
| CUSTOMER SERVICE | 10 |

Introduction

The HDTools™ **HWCE Tx/Rx** is a single-gang HDMI and USB 2.0 Wall Plate Extension System providing Ultra HD/4K signal transmission over a single CATx cable to distances up to 130 ft. The HWCE Tx/Rx can also transmit 3.5mm analog audio independent from the HDMI or USB input source. The HWCE is HDMI 1.4 and HDCP 2.2 compliant and supports CEC, as well as one-way RS-232 pass-through.

Product Features

- HDMI, 3.5mm audio, and USB 2.0 extension over HDBaseT™
- Supports resolutions up to 4K@60Hz (4:2:0)/4K@30Hz (4:4:4)
- Supports HDR (High Dynamic Range) content
- HDCP 2.2 & HDMI 1.4 compliant
- Supports distances up to 130 ft. (40m) at Ultra HD/4K and 230 ft. (70m) at 1080p
- Independent analog audio signal transmission
- RS-232 & CEC pass-through
- Remote power from receiver to transmitter
- Standard US 1-Gang Decora format (Tx)

Package Contents

- 1 x HWCE Wall Plate Transmitter
- 1 x HWCE HDBaseT Receiver
- 1 x Phoenix connector (3 pins)
- 1 x Phoenix connector (2 pins)
- 1 x 24V/1A power adapter
- 1 x Cover plate
- 2 x Rack ears

Specifications

| Performance | |
|-----------------------|--|
| HDMI Compliance | HDMI 1.4 |
| HDCP Compliance | HDCP 2.2 |
| Supported Data Rate | 10.2 Gbps |
| Supported Resolutions | 4K2K@50/60Hz 4:2:0, 4K2K@30Hz 4:4:4 1080P@120Hz, and 1080P 3D@60Hz |
| Color Space | RGB/YCbCr 4:4:4, YCbCr 4:2:2 |
| Color Depth | 8-bit, 10-bit, 12-bit |
| HDMI Audio Formats | LPCM, Dolby Digital/Plus/EX, Dolby True HD, DTS,DTS-EX,DTS-96/24, DTS High Res, DTS-HD Master Audio, DSD |
| Analog Audio Formats | LPCM 2CH, LPCM 5.1, Dolby Digital 2/5.1CH, DTS 2/5.1CH |
| ESD Protection | Human body model—±8kV (Air-gap discharge) &±4kV(Contact discharge) |
| Connections | |
| Transmitter (HWCE Tx) | Inputs: (1) HDMI Type A [19-pin female] (1) AUDIO IN [3.5mm earphone] (1) USB [USB-B] (1) RS-232 [3-pin phoenix] (1) DC 24V/GND [2-pin phoenix] Outputs: (1) HDBaseT OUT [RJ45] |
| Receiver (HWCE Rx) | Inputs: (1) HDBaseT IN [RJ45] (1) DC 24V [locking power] Outputs: (1) HDMI Type A [19-pin female] (1) AUDIO OUT [3.5mm earphone] (1) RS-232 [3-pin phoenix] (2) USB [USB-A] |
| Enclosure | |
| Housing | Metal enclosure |
| Color | TX: White decora wall plate RX: Black, powder coat finish |
| Product Weight | TX: 0.36 lbs. RX: 0.44 lbs. |
| Product Dimensions | TX: 4.0 x 1.8x 1.2 in. RX: 5.6 x 2.9 x 0.9 in. |
| Power Supply | Input: AC100 - 240V 50/60Hz, Output: DC 24V/1A (US/EU standards, CE/FCC/UL certified) |
| Power Consumption | 9W (max) |
| Operating Temperature | 32 - 104°F / 0 - 40°C |
| Storage Temperature | -4 - 140°F / -20 - 60°C |
| Relative Humidity | 20 - 90% RH (no condensation) |

Operation & Control Functions

Transmitter (Front Panel)

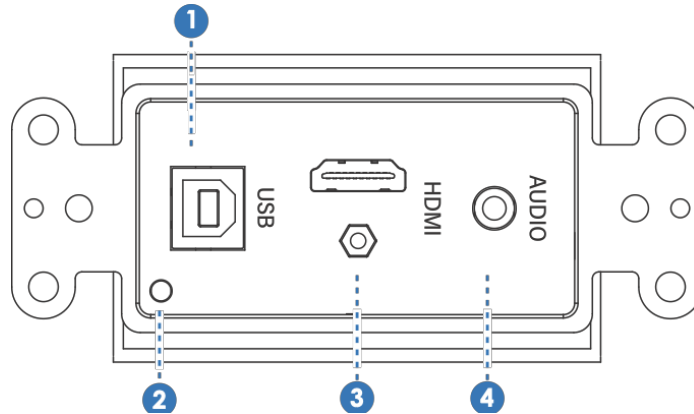

| Name | Function |
|----------------|---|
| 1 – USB | USB 2.0 Type-B port |
| 2 – ACTIVE LED | GREEN light indicates that an HDMI signal input is detected. When no signal is detected, the light will remain off. |
| 3 – HDMI | Connect to HDMI sources |
| 4 – AUDIO | Analog Audio input port |

Transmitter (Rear Panel)

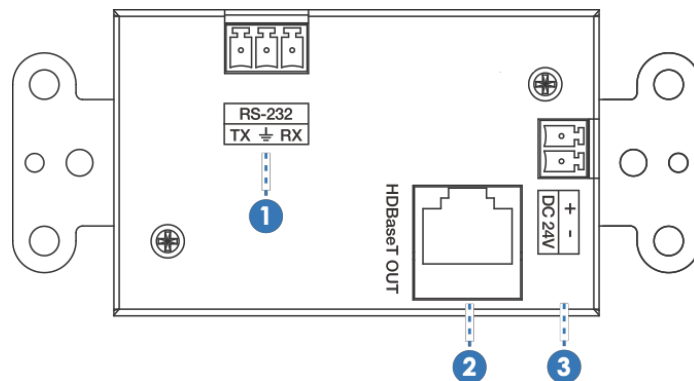

| Name | Function |
|-----------------|---|
| 1 – RS-232 | Phoenix connector for RS-232 control |
| 2 – HDBaseT OUT | HDBaseT output port – connect HWCE receiver with a CATx cable |
| 3 – DC 24V | Phoenix connector for reserved power supply |

Receiver (Front & Back Panels)

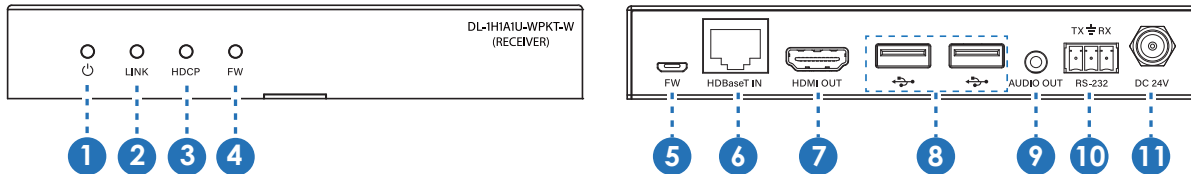

| Name | Function |
|-----------------------|---|
| 1 – Power LED | When the power supply is normal, the indicator light will turn on |
| 2 – LINK LED | LINK status indicator light |
| 3 – HDCP LED | HDCP status indicator light |
| 4 – F/W LED | When device is working properly, the indicator light will turn on |
| 5 – F/W | Micro-USB port for firmware updates |
| 6 – HDBaseT IN | HDBaseT input port – connect HWCE transmitter with a CATx cable |
| 7 – HDMI OUT | HDMI output port – connect display device |
| 8 – USB | Connect USB device (mouse/keyboard) |
| 9 – AUDIO OUT | Analog Audio output port |
| 10 – RS-232 | Phoenix connector RS-232 control |
| 11 – DC 24V | Connect 24V 1A power adapter to AC wall outlet |

Application Examples

POC (Power over Cable) Application

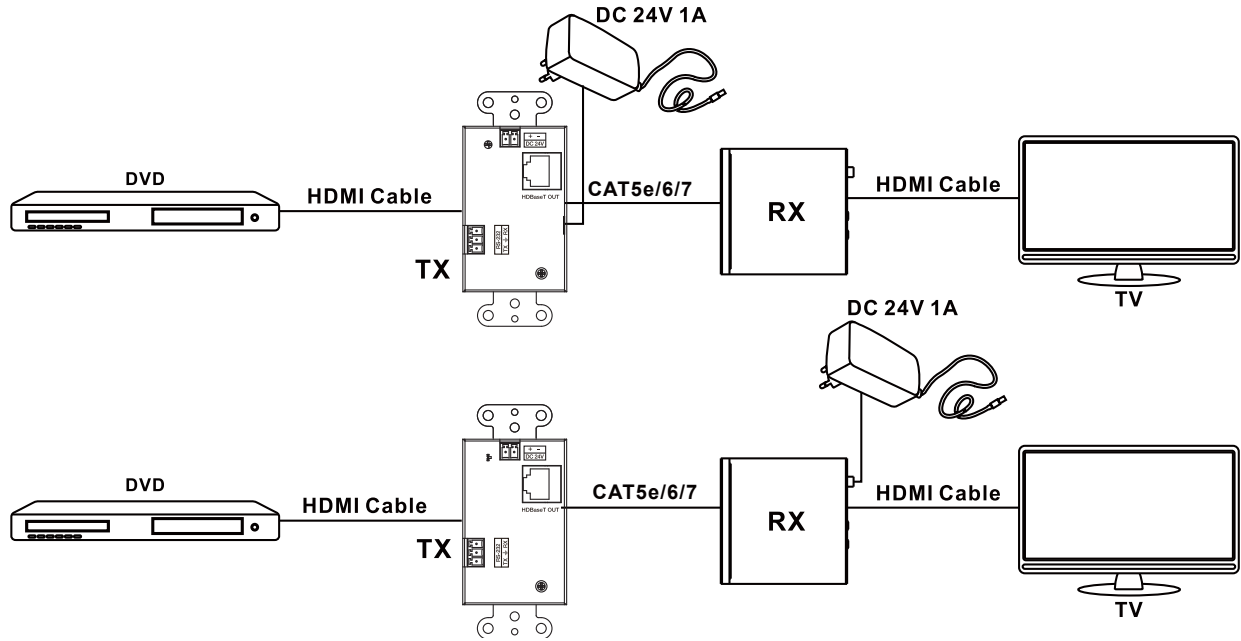

Bidirectional RS-232 Control Application

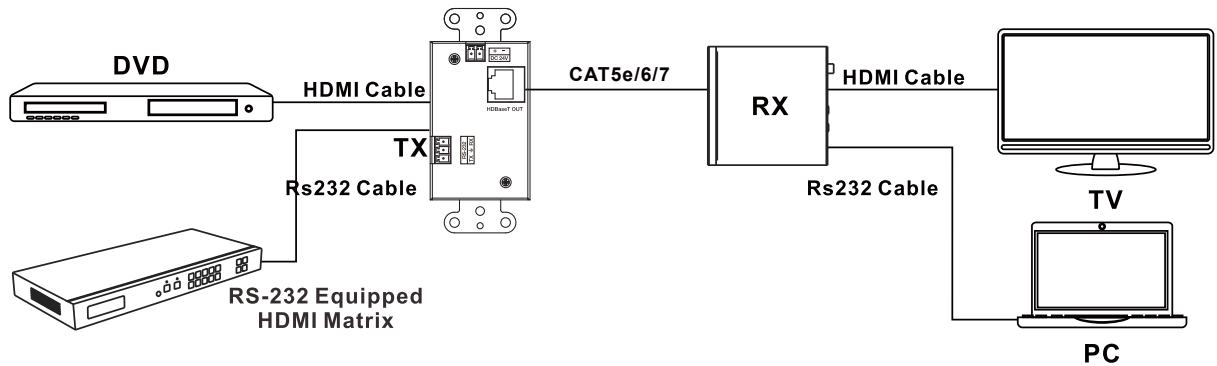
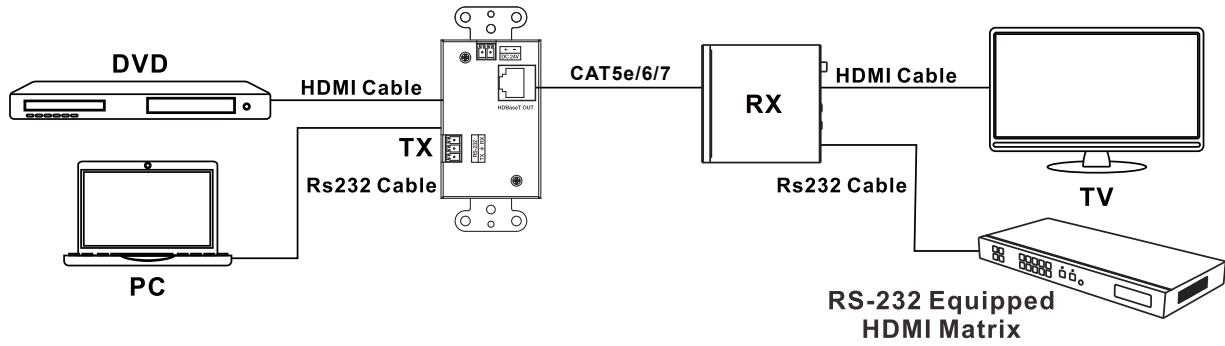

Warranty

PureLink™ Three (3) Year Limited Warranty

For HDTools™ & PureStream™ Branded Products Only

Dtrovision, LLC. (hereinafter “PureLink”) warrants its HDTools™ and PureStream™ branded products (hereinafter “Product”) purchased directly from PureLink or Dealer shall be free from defects in workmanship and materials, under normal use and service, for a period of three (3) years on parts and three (3) years on labor. Any repaired or replaced equipment related to Product shall be covered only under the remaining portion of the warranty. This warranty has no relationship to and exists independently of any warranty offered by Dealer. This warranty is a limited warranty and gives you specific legal rights. You may also have other rights which vary from state to state.

TERMS & CONDITIONS

PureLink shall repair or replace the Product if it develops a material fault during the period of warranty, on condition that i) the Product has only been subject to normal use in a domestic or commercial environment in a manner consistent with its specification and functionality, ii) the Product has been cared for reasonably and only subjected to reasonable wear and tear, iii) the defect has not been caused by willful or negligent abuse or neglect, or any accident or improper installation procedure, iv) the serial number of the Product has not been altered or removed.

This warranty only applies to the original purchaser, and shall be the exclusive remedy to the original purchaser. PureLink shall not be liable for any damages whatsoever caused by Product or the failure of Product to perform, including incidental or consequential damages. PureLink shall not be liable for any claim made by a third party or made by the purchaser for a third party.

Except as expressly set forth in this warranty, PureLink makes no other warranties, expressed or implied, including any implied warranties of merchantability and fitness for a particular purpose. PureLink expressly disclaims all warranties not satisfied in this limited warranty. Any implied warranties that may be imposed by law are limited to the terms of this limited warranty. This warranty statement supersedes all previous warranties.

WARRANTY RETURNS/REPAIRS/EXCHANGES

No merchandise may be returned without prior authorization from PureLink, and a Return Materials Authorization (RMA) number. Failure to comply with these conditions will result in rejection of the returned merchandise.

Any warranty service on Products must be arranged through Dealer. Authorized returns must be shipped freight prepaid and fully insured to PureLink, Ramsey, NJ USA, with the RMA number clearly marked on the outside of all shipping boxes and containers. PureLink reserves the right at its sole discretion to refuse any shipments arriving freight collect or without an RMA number. Any authorized returned merchandise must be accompanied by a note describing the reason for return, along with contact information including name, phone number, return mailing and shipping addresses, e-mail address, and RMA number.



On any products returned and accepted with an RMA number, return freight charges following repair of items under warranty shall be paid by PureLink, shipping by the standard ground carrier of its choice.

ADVANCE WARRANTY REPLACEMENTS

PureLink's advance replacement service offers a Replacement Unit upon request - free of charge for eligible products purchased less than one (1) year of the warranty claim. Products purchased more than one (1) year prior to the warranty claim do not qualify for advance replacement services.

Advance replacement requests must be validated by a member of PureLink's Technical Support Team. Replacement units may be new or refurbished and is subject to availability. PureLink is responsible for shipping the Replacement Unit to your designated location by standard ground service. All other shipping methods will be responsibility of the Dealer.

Original Unit Return – the Original Unit must be returned within thirty (30) calendar days of the return authorization date. Failure to return the Original Unit within this period will be subject to a minimum 15% re-stocking fee. Dealer is solely responsible for the shipping of the Original Unit to PureLink.

TO MAKE A WARRANTY CLAIM

To make a warranty claim, promptly notify PureLink within the warranty periods described above by calling PureLink's Technical Support Department at 1-201-488-3232. PureLink, in its sole discretion, will determine what action, if any, is required under this warranty.

Customer Service

Most problems can be corrected over the phone through close cooperation between Customer and a PureLink technician. To better enable PureLink to address a warranty claim, please have the Product's serial and model numbers. If PureLink, in its sole discretion, determines that an on-site visit or other remedial action is necessary, PureLink may send a representative to Customer's site.

CUSTOMER SERVICE

Technical support inquiries can be submitted electronically at www.purelinkav.com. For immediate assistance please contact PureLink's Customer Care Team at +1 (201) 488-3232.