



**VIP-CAM-20-10x-USB2**  
**PTZ CAMERA w/HDMI & USB Output**  
USER MANUAL



PureLink™  
22-10 State Route 208  
Fair Lawn, NJ 07410 USA  
Tel: +1.201.488.3232  
Fax: +1.201.621.6118  
E-mail: [sales@purelinkav.com](mailto:sales@purelinkav.com)

For order support, please contact your local dealer.  
For technical support, please contact us at [support@purelinkav.com](mailto:support@purelinkav.com)

---

## Safety Precautions

- Before installing the device, please read this manual carefully and follow instructions indicated to ensure proper operation. Please keep this manual for future reference.
- Before powering on the device, please check the input power voltage carefully, the camera accepts DC5V, otherwise, it may cause damage to the camera.
- Please install USB cable, HDMI and control cables clear from devices or other cables that might cause malfunction to the device.
- Please the working environment meets the conditions of the device operating temperatures of 0°C~+40°C , and humidity at < 90%.
- Please avoid shock, and vibration that may cause damage to the camera.
- Please only refer to authorized personnel to repair the device, do not disassemble the camera by yourself.
- Do not aim the camera lens at direct sunlight or strong lights that may cause damage to the imaging system of the device.
- Please use soft optics rated cloth to clean the device, do not use strong or abrasive detergent to clean that will damage the device's housing / lens.

---

# Table of Contents

<b>PRODUCT OVERVIEW</b>	<b>1</b>
<b>FEATURES</b>	<b>1</b>
<b>PACKING LIST</b>	<b>1</b>
<b>MAIN PARTS AND CONTROL INTERFACES</b>	<b>2</b>
<b>REMOTE CONTROL</b>	<b>3</b>
<b>INSTALLATION</b>	<b>5</b>
<b>DESKTOP MOUNT INSTALLATION</b>	<b>5</b>
<b>WALL MOUNT INSTALLATION</b>	<b>5</b>
<b>CONNECTIONS</b>	<b>6</b>
<b>ON SCREEN DISPLAY MENUS</b>	<b>7</b>
<b>ANNEX 1 TECHNICAL SPECIFICATIONS</b>	<b>11</b>
<b>ANNEX 2 SIZE AND DIMENSION</b>	<b>12</b>
<b>TROUBLESHOOTING</b>	<b>11</b>
<b>WARRANTY</b>	<b>ERROR! BOOKMARK NOT DEFINED.</b>

---

# PRODUCT OVERVIEW

---

## Features

- 2.12MP, 1/2. 9" CMOS sensor;
- Standard UVC protocol;
- USB2.0 high speed output, up to 1920x1080P30;
- Support H.264, MJPEG compressed video output;
- Supports one channel audio input;
- 3x optical zoom, synchronized focus lens;
- 80 ° horizontal view;
- With multi-function IR remote control;
- Power consumption <2W, support USB direct power supply;

---

## Packing List

When you open the package, please make sure below items are included. If any items are missing, please contact your supplier.

### PTZ Camera (1)

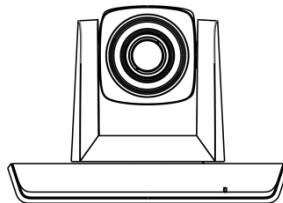

### Remote Control x 1

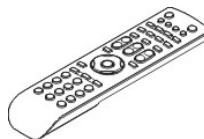

### USB Cable x 1

**110-240 VAC 50/60Hz 12Vdc power adapter X 1**

# Main Parts and Control Interfaces

## PTZ Camera

### Front View

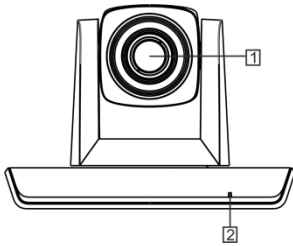

- 1 Camera Module
- 2 Power Indicator

### Rear View

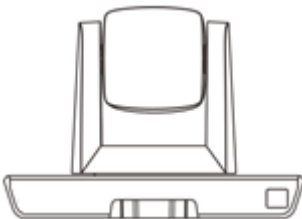

### Bottom View

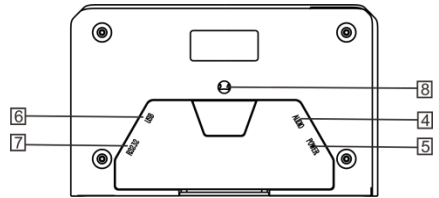

- 4 Power
- 5 HDMI
- 6 USB interface
- 7 RJ45 Control Port (RS232)
- 8 Tripod Mounting hole 1/4"

Pin Definition of Control Port	
Pin No	Definition
1	/
2	/
3	TX
4	GND
5	RX
6	/
7	/
8	/

# Remote Control

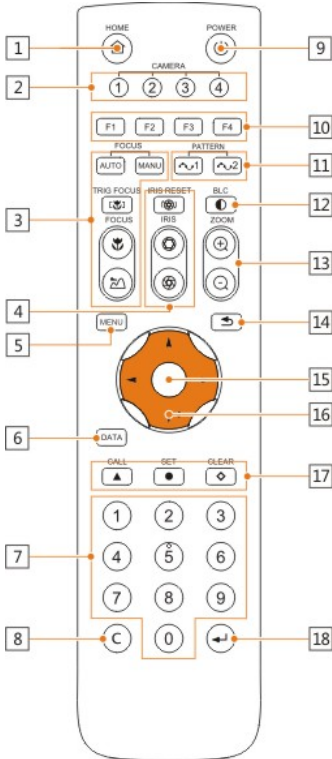

## 1 HOME button

Press **HOME** button, camera moves to initial position where both pan and tilt angle is zero.

## 2 Camera Selection Button

Used to switch among 4 cameras, press 1-4 number buttons to control cameras with 1-4 address respectively. For example, press button 1 to control the camera with address 1.

## 3 Focus

Press for near focus.

Press for far focus.

Press to trigger auto focus

## 4 Iris

Press "" button to reset brightness value to default. "" button to increase brightness, "" button to decrease brightness.

## 5 Menu

Displays OSD setup menu on both USB and HDMI outputs.

## 6 Data

Reserved for VIP-CAM-100 series.

## 7 Number Keys

Used to input numbers, for example, preset number.

## 8 Cancel

Used to delete number inputted.

## 9 Power

After the camera has been connected to power source, press this button to turn on / off the camera.

#### **10 Reserved buttons ( F1, F2, F3, F4 )**

These buttons are reserved for future use.

#### **11 Pattern**

Reserved for VIP-CAM-100 series.

#### **12 BLC**

Used to open / close back light compensation.

#### **13 Zoom**

Used to adjust zooming times.

“” button to zoom in

“” button to zoom out.

#### **14 Back**

Return function for OSD.

#### **15 OK**

OSD confirmation.

#### **16 Direction Operation**

Press these four buttons to pan left/right and tilt up/down.

#### **17 Preset Setting**

“” button to call a preset.

Input number key(s), and press to call a preset.

“” button to set a preset.

Move the camera to PTZ value etc., and press to set a preset.

“” button to clear a preset.

Input preset number and press to clear a preset.

#### **18 Enter**

After entering numbers, press this button to confirm.

---

# INSTALLATION

The camera has 3 installation types:  
desktop, wall mount, and ceiling mount.

### Note



Make sure the installed place is strong and safe enough to hold the camera and relative parts.

---

## Desktop Mount Installation

1. Put the camera on a flat surface. In case the camera has to be placed on an inclined surface, make sure the cline angle is less than 15 degrees to ensure proper pan /tilt operation.

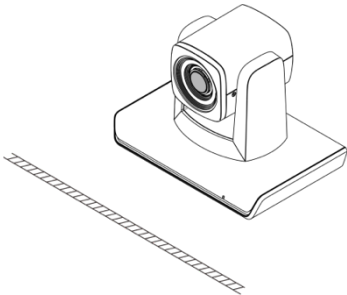

### Note



Avoid dropping camera

- Do not grab the camera by the head
- Do not rotate the camera head with hand. It may cause the camera to malfunction.

---

## Wall Mount Installation

(Bracket optional)

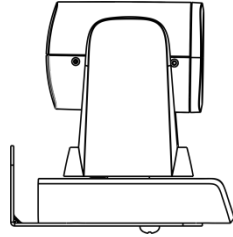

1. According to diameter and position of the 2 installation holes (As shown below) on the bracket, drill 2 holes on the wall and fix the bracket.

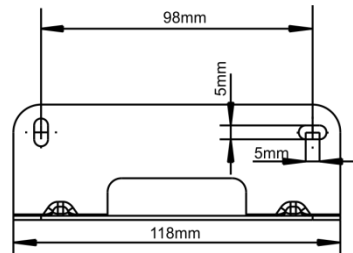

2. Use screws to fix the camera on the bracket. Make sure the camera is tightly fixed onto the bracket before your hands leave the camera.

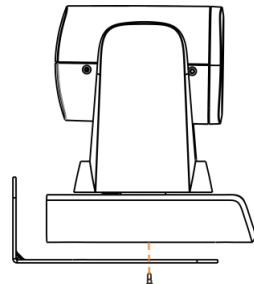



---

## Connections

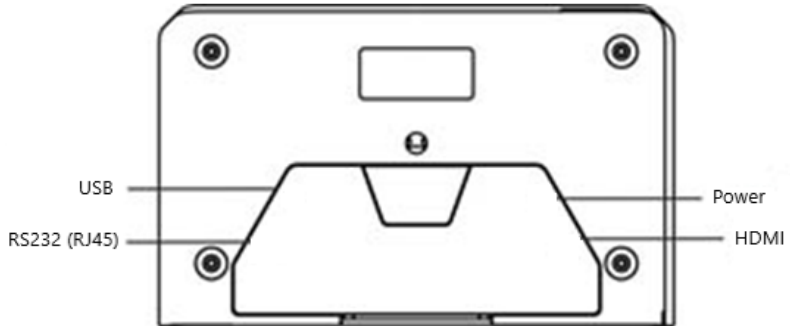

### **USB: Video and control**

Connect the supplied USB-A to USB-A cable.

### **RS232 control**

Please see the diagram for correct wiring of the RS232 control using the RJ45 jack.

### **Power**

Connect the supplied 12VDC power adapter

### **HDMI**

Connect an HDMI cable

---

# On Screen Display Menus

## Top Level Menu

VIDEO

EXPOSURE

WHITE BALANCE

PAN TILT ZOOM

SYSTEM

STATUS

RESTORE DEFAULT

### VIDEO Menu

— SHARPNESS —	0, 1, 2, 3, 4, 5, 6, 7, 8, 9, 10, 11, 12, 13, 14, 15
— CONTRAST —	1, 2, 3, 4, 5, 6, 7, 8, 9, 10, 11, 12, 13, 14, 15
— SATURATION —	1, 2, 3, 4, 5, 6, 7, 8, 9, 10, 11, 12, 13, 14
— HUE —	1, 2, 3, 4, 5, 6, 7, 8, 9, 10, 11, 12, 13, 14
— 2DNR LEVEL —	ON, OFF
— 3DNR LEVEL —	AUTO, 1, 2, 3, 4, OFF
— WIDE DYNAMIC —	ON, OFF

## EXPOSURE Menu

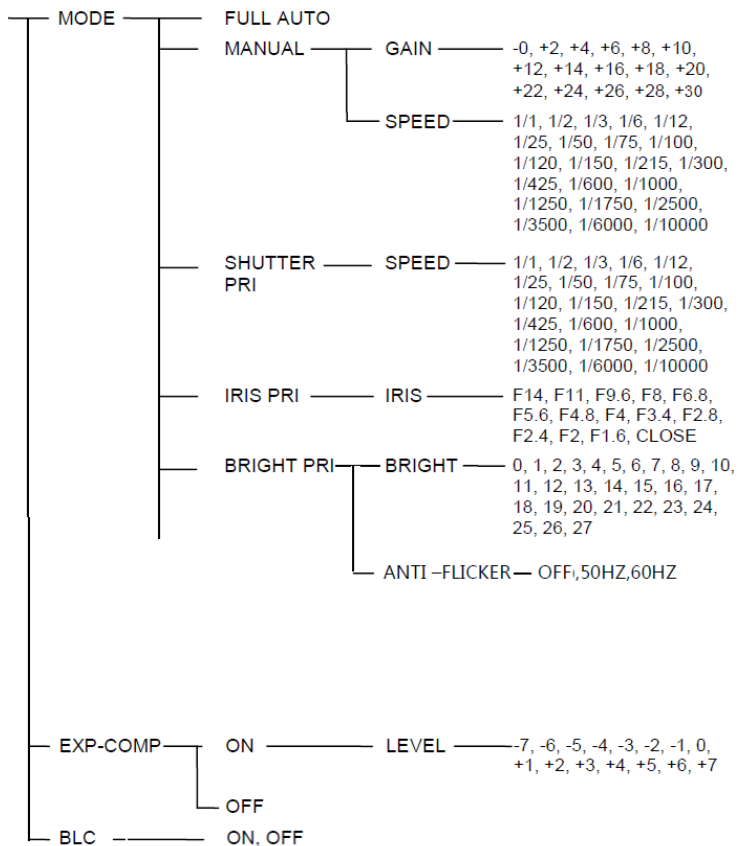

## WHITE BALANCE Menu (COLOR)

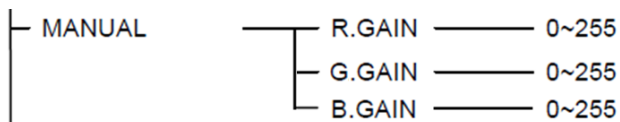

### Pan Tilt Zoom Menu

PAN/TILT SPEED	—	1, 2, 3, 4, 5, 6, 7, 8
PAN/TILT LIMIT	—	ON, OFF
UP	—	-30°~+90°
DOWN	—	-30°~+90°
LEFT	—	-170°~+170°
RIGHT	—	-170°~+170°
D-ZOOM LIMIT	—	X1, X2, X3, X4, X5, X6, X7, X8, X9, X10, X11, X12
PTZ TRIG AF	—	ON, OFF
RATIO SPEED	—	ON, OFF
POWER UP ACTION	—	PRESET 1, PRESET 2, PRESET 3, PRESET 4, PRESET 5, PRESET 6, PRESET 7, PRESET 8, PRESET 9. HOME

### System Menu

PAN/TILT SPEED	—	1, 2, 3, 4, 5, 6, 7, 8
PAN/TILT LIMIT	—	ON, OFF
UP	—	-30°~+90°
DOWN	—	-30°~+90°
ADDRESS		1, 2, 3, 4, 5, 6, 7
PROTOCOL		VISCA, PELCO-P, PELCO-D
BAUDRATE		2400, 4800, 9600, 38400
VIDEO FORMAT		1080P60, 1080P50, 1080I60, 1080I50, 1080P30, 1080P25, 720P60, 720P50
MOUNT MODE		STAND, CEILING
LANGUAGE		ENGLISH, CHINESE    ♪-DUPLEX-2

## Status Menu

ADDRESS	1
PROTOCOL	VISCA
BAUDRATE	9600
MOUNT MODE	STAND
IMAGE VER	V6629
FIRMWARE VER	V1.0.0

## RS232 wiring

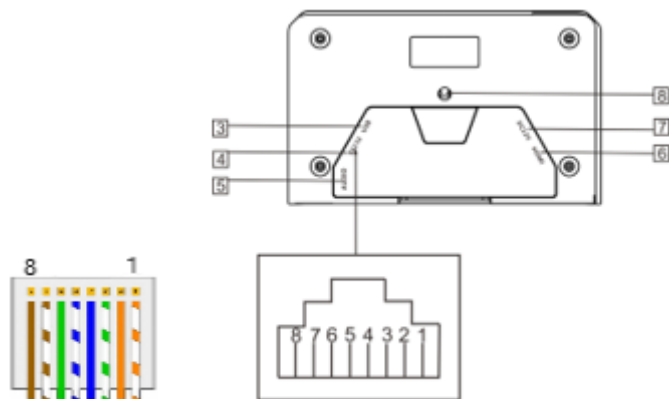

Blue Ground

Green TX

Green/White RX

# TECHNICAL SPECIFICATIONS

<b>VIDEO</b>	
Image Sensor	1/2.9" CMOS, 2.12megapixel
Video Format	1080P30 fps
Compression	H.264\MJPEG\YUY2
Focal Lens	f=3mm-10mm
Iris	F1.4
Optical Zoom	3X
Field of View	80°~28°
Focus System	Svnc focus
Exposure Control	Auto/ Manual.
White Balance	Auto/ Manual.
Min. illumination	0.5 lux (color) 0.1 lux (B/W)
BLC	Support
S/N Rate	≥50dB
<b>PTZ</b>	
Pan Angle	-90°~+90°
Tilt Angle	-30°~+90°
Pan Speed	18°/S
Tilt Speed	18°/S
Preset Number	32
<b>Interface</b>	
Video Output	USB2.0
Audio Port	Line IN
Control Interface	USB2.0, RS-232
UVC Protocol	UVC 1.0-UVC 1.5
UVC PTZ Control	Support
Infrared Remote Control	Support
<b>General</b>	
Protocol	VISCA
Address	1~7
Power	DC5V
Power Consumption	< 2W
Operating Temperature	0°C ~ + 40°C
Storage Temperature	-20°C~+60°C
Dimensions (W×D×H)	163 mm×101 mm×114mm
Weight	0.6KG
Body Color	Black

# SIZE AND DIMENSIONS

**Front**

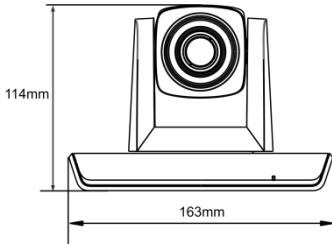

**Rear**

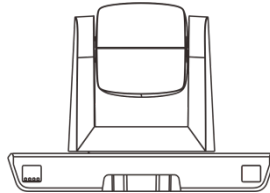

**Top**

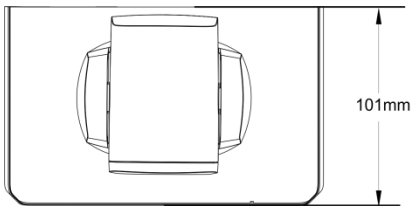

**Side**

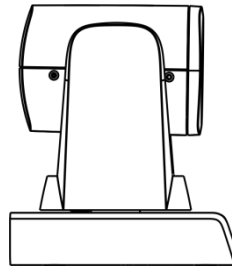

**Bottom**

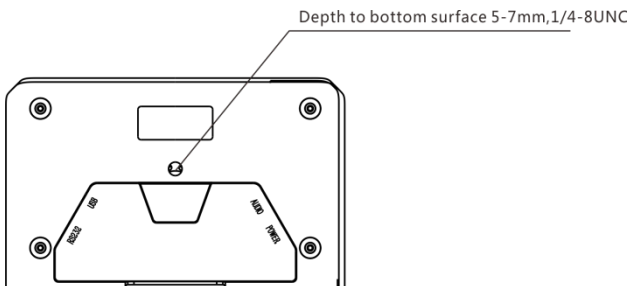

---

# TROUBLESHOOTING

Problem	Possible Cause	Solution
No action or image after powered on,	Power supply failure	Check power supply
	Power adapter damaged	Replace power adapter
No self-testing after powered on, or with	Power cable connection got loosen	Check & reconnect
	Mechanical failure	Repair
Not controllable from IR remote controller	Low battery of remote controller	Change battery for remote controller
	Exceed remote control distance	Control within distance of 8M
After power on, self-test successfully, but not controllable	Wrong address / protocol / baud rate	Check & set again
	Wrong connection or open circuit of RS-232 cable	Check & reconnect



---

# WARRANTY

## PureLink Three (3) Year Limited Warranty for PureStream™ Branded Products

Dtrovision, LLC. (hereinafter "PureLink") warrants its HDTools and PureStream™ branded products (hereinafter "Product") purchased directly from PureLink or Dealer shall be free from defects in workmanship and materials, under normal use and service, for a period of three (3) years on parts and three (3) years on labor. Any repaired or replaced equipment related to Product shall be covered only under the remaining portion of the warranty. This warranty has no relationship to and exists independently of any warranty offered by Dealer. This warranty is a limited warranty and gives you specific legal rights. You may also have other rights, which vary from state to state.

### TERMS & CONDITIONS

PureLink shall repair or replace the Product if it develops a material fault during the period of warranty, on condition that i) the Product has only been subject to normal use in a domestic or commercial environment in a manner consistent with its specification and functionality, ii) the Product has been cared for reasonably and only subjected to reasonable wear and tear, iii) the defect has not been caused by willful or negligent abuse or neglect, or any accident or improper installation procedure, iv) the serial number of the Product has not been altered or removed.

This warranty only applies to the original purchaser, and shall be the exclusive remedy to the original purchaser. PureLink shall not be liable for any damages whatsoever caused by Product or the failure of Product to perform, including incidental or consequential damages. PureLink shall not be liable for any claim made by a third party or made by the purchaser for a third party.

Except as expressly set forth in this warranty, PureLink makes no other warranties, expressed or implied, including any implied warranties of merchantability and fitness for a particular purpose. PureLink expressly disclaims all warranties not satisfied in this limited warranty. Any implied warranties that may be imposed by law are limited to the terms of this limited warranty. This warranty statement supersedes all previous warranties.

### WARRANTY RETURNS/REPAIRS/EXCHANGES

No merchandise may be returned without prior authorization from PureLink, and a Return Materials Authorization (RMA) number. Failure to comply with these conditions will result in rejection of the returned merchandise.

Any warranty service on Products must be arranged through Dealer. Authorized returns must be shipped freight prepaid and fully insured to PureLink, Ramsey, NJ USA, with the RMA number clearly marked on the outside of all shipping boxes and containers. PureLink reserves the right at its sole discretion to refuse any shipments arriving freight collect or without an RMA number. Any authorized returned merchandise must be accompanied by a note describing the reason for return, along with contact information including name, phone number, return mailing and shipping addresses, e-mail address, and RMA number.

On any products returned and accepted with an RMA number, return freight charges following repair of items under warranty shall be paid by PureLink, shipping by the standard ground carrier of its choice.

### ADVANCE WARRANTY REPLACEMENTS

PureLink's advance replacement service offers a Replacement Unit upon request - free of charge for eligible products purchased less than one (1) year of the warranty claim. Products purchased more than one (1) year prior to the warranty claim do not qualify for advance replacement services.

Advance replacement requests must be validated by a member of PureLink's Technical Support Team. Replacement units may be new or refurbished and is subject to availability. PureLink is responsible for shipping the Replacement Unit to your designated location by standard ground service. All other shipping methods will be responsibility of the Dealer.

**Original Unit Return** – the Original Unit must be returned within thirty (30) calendar days of the return authorization date. Failure to return the Original Unit within this period will be subject to a minimum 15% re-stocking fee. Dealer is solely responsible for the shipping of the Original Unit to PureLink.

#### **TO MAKE A WARRANTY CLAIM**

To make a warranty claim, promptly notify PureLink within the warranty periods described above by calling PureLink's Technical Support Department at 1-201-488-3232. PureLink, in its sole discretion, will determine what action, if any, is required under this warranty.

Most problems can be corrected over the phone through close cooperation between Customer and a PureLink technician. To better enable PureLink to address a warranty claim, please have the Product's serial and model numbers. If PureLink, in its sole discretion, determines that an on-site visit or other remedial action is necessary, PureLink may send a representative to Customer's site.

#### **CUSTOMER SERVICE**

Technical support inquiries can be submitted electronically at [purelinkav.com/tickets](https://purelinkav.com/tickets). For immediate assistance please contact PureLink's Customer Care Team at **+1 (201) 488-3232**